

mono[®]

HINGE

SELF CLOSING GATE



Installation & Maintenance Instructions

DOUBLE GATE MODEL

**JOSEPH
ASH**
GALVANIZING | MEDWAY

Contact us today for more information:

Joseph Ash Medway

01795 479489

monhingegates@josephash.co.uk

www.josephash.co.uk

INSTALLATION INSTRUCTIONS – SELF CLOSING GATE® MODEL 38L(LEFT)/ 38R(RIGHT) 1000mm & 1200mm High

GATE OPENING

WE RECOMMEND THE GATES OPEN OUT OF THE PLAY AREA for the following reasons:

1. To avoid the risk of collision with children already in the play area.
2. To slow children entering the play area.
3. To stop dogs from pushing the gate open.

INSTALLATION

When maneuvering the gate/components during transport and installation DO NOT lift by the gate leaf. This could lead to the Ryobi insert disengaging. (Please see trouble shooting.)

Excavate a trench that is suitable for your requirements. See diagram [Fig.1](#) for our suggested dimensions.

Position the gate in the excavation, vertical in both planes, ensuring correct alignment with the adjacent fencing. Concrete the gate in position, USING A STRONG WET MIX (standard prescribed mix ST5 to BSEN8500) and accelerator if required. Finish off the top surface to the ground level marker.

When the gate is in place, adjust it to your recommended speed - see [Fig.2](#) for speed adjustment instructions.

IMPORTANT DIMENSIONS TO FOLLOW

1. The distance between the hinge post and the adjacent fencing must be greater than 30mm and less than 80mm. The maximum gap between the gate and the adjacent fencing is 80mm.
2. The distance between the bottom of the gate leaf and ground level should be 80mm throughout the swing area, as indicated by the ground level marker.
3. The gate leaf must be clear of any obstructions throughout its swinging area and have a clearance of at least 30mm from the adjacent fencing or other objects.

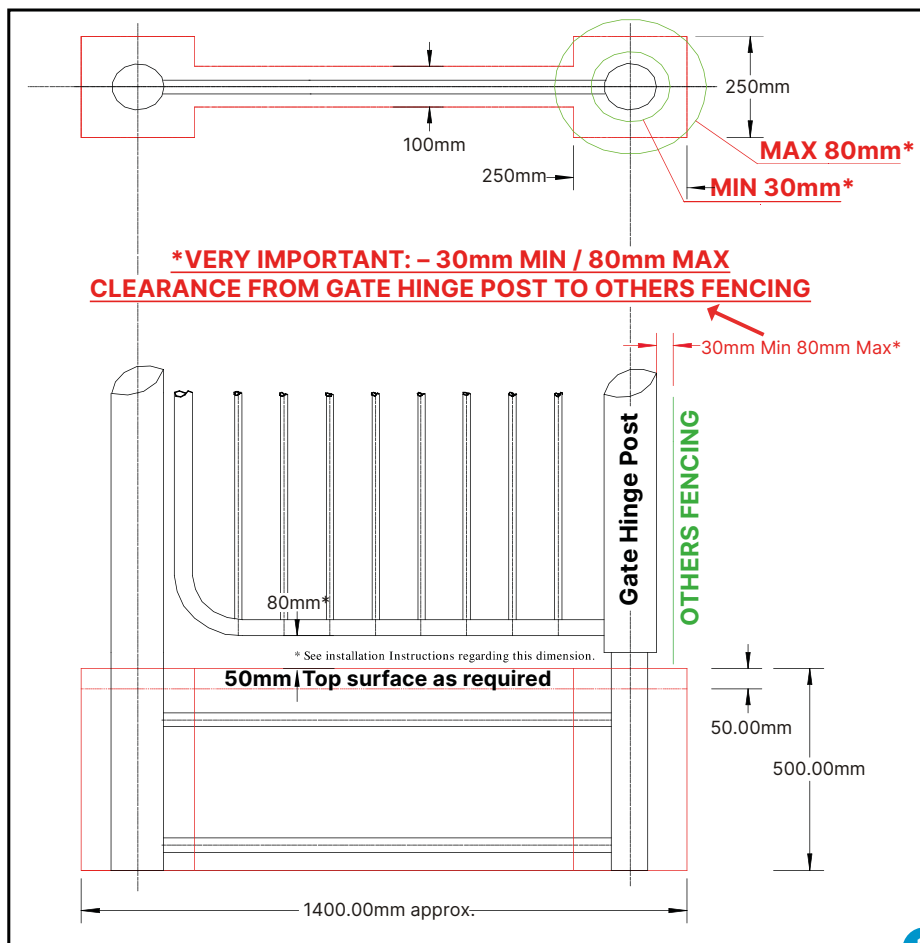

INSPECTION

Before placing the gate into operation an overall inspection should be carried out, including but not inclusive of:

- Security and condition of post caps
- Security and condition of the bottom bearing
- Sharp surfaces
- Damaged or bent components
- Suitable opening and closing of the gate
- Correct distance from adjacent fencing and any obstructions
- Stability and security of the Self Closing Gate® unit.

SPEED ADJUSTMENT

To adjust the speed, first remove the security screws from the top cap of the post. (There are four security screws which will require a U10 Key available from Joseph Ash Medway.) Once the screws are removed, gently knock the top cap using a hide mallet or equivalent until it lifts off. Please refer to the sketch below for speed adjustments.

Note – NEVER wind the Ryobi fully clockwise as this WILL cause the hydraulic med to leak, and the gate damping will cease to function which, in turn, will be chargeable. Reassemble in reverse.

GENERAL MAINTENANCE

The pins that support the gate hinge post should be oiled regularly. To do this, remove the top cap and apply a small amount of oil onto the three visible pins.

The bearing situated at the bottom of the gate hinge post requires greasing at regular intervals. Remove one security screw and inject grease into the threaded opening to grease the bearing. Then, replace the screw and tighten it. Repeat the same process for each of the remaining three security screws taking care to grease one at a time to ensure minimal sudden movement in the gate and the parts getting damaged.

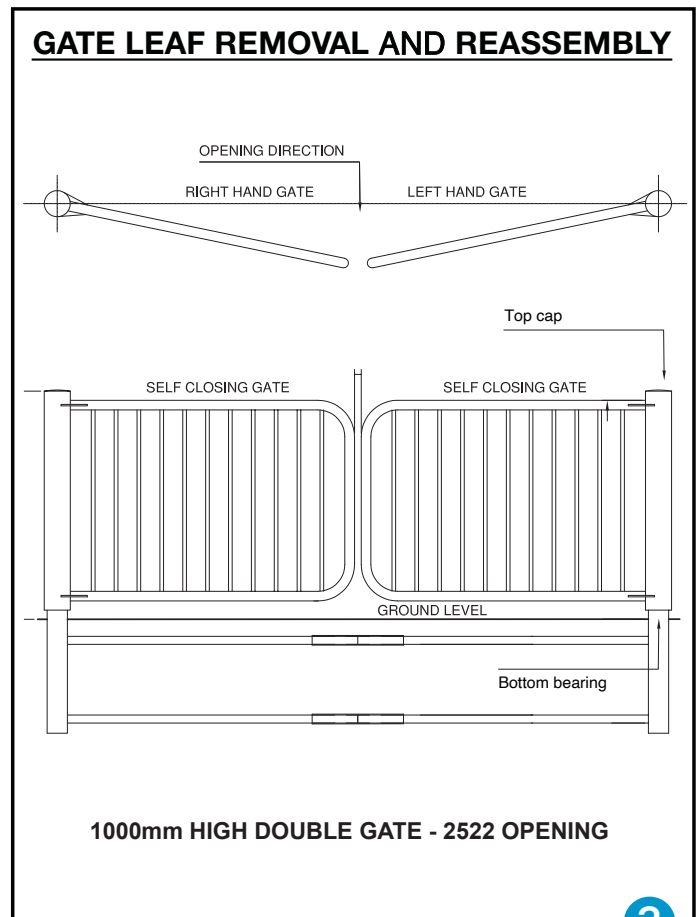
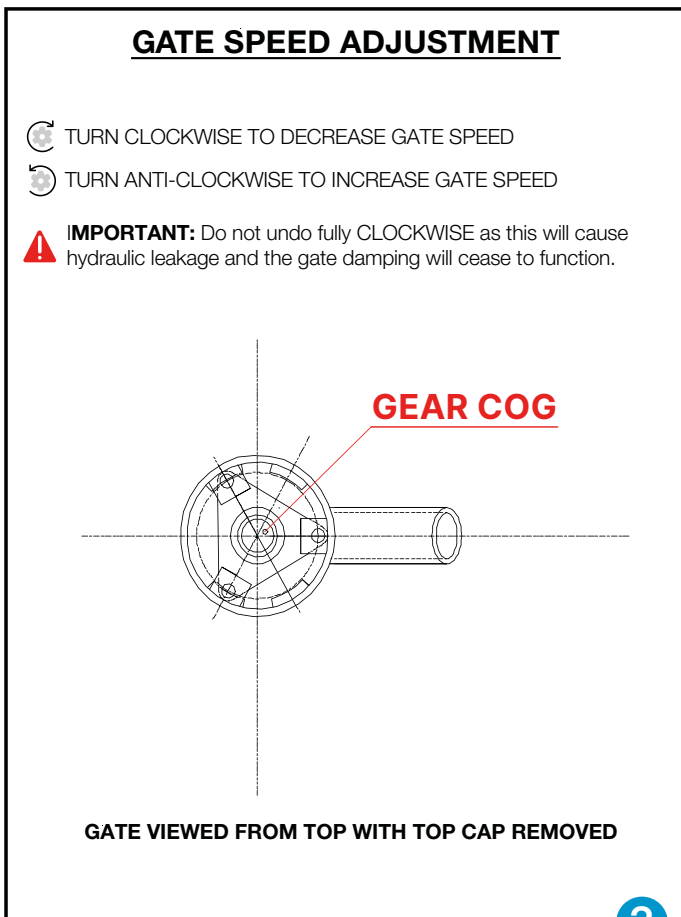

GATE LEAF REMOVAL AND REASSEMBLY INSTRUCTIONS FOR THE MONO HINGE SELF CLOSING GATE®

TOOLS REQUIRED

U10 Key and Hide Mallet.

Before removing the top cap shown in Fig. 4 take note of the exact position to enable easy refitting. Then remove the top cap by undoing the four security screws. If necessary, gently knock the top cap upwards with a hide mallet until it is free.

Remove the 'bottom bearing' by removing the four security screws and gently rock the gate leaf until the bottom bearing drops.

The gate leaf is now ready for removal. Lift the gate leaf until the three drive pins on the gate damper are free.

Remove the Damper/Ryobi Unit by lifting it from the top of the internal post* and replacing it with the service exchange.

To set the gate Ryobi Insert to a standstill, adjust the speed adjustment cog clockwise until the mechanism, when turned by hand, is at a standstill. (Trial and error are essential here, taking care not to remove the cog altogether.)

Grease the area around the internal post where the 'bottom bearing' comes into contact with its stop bolt.

Refit the gate leaf in the reverse of the removal process, and when engaged with the three pins, refit the bottom bearing. (Please note: One pin is highlighted. The length of the gate leaf must align with this pin, and you must fit the gate in the open position.) Align the tapped holes with the post holes and push the 'bottom bearing' into the post. (A small Allen key helps to align the holes in the post with the bearing.) Replace the four security screws which retain the bearing.

Adjust the speed adjustment cog anticlockwise until the gate closes at your desired speed.

Replace the top cap and secure it with the four security screws.

* If you are changing the Ryobi only, remove the Damper/Ryobi Unit by lifting it out of the post. Tap the end of the Ryobi gently and remove it with care. Replace with the exchange unit and reassemble in reverse, ensuring the thrust race is clean and greased.

